



MILTON AND TAMAR MALTZ
Performing Arts Center at
The Temple-Tifereth Israel
CASE WESTERN RESERVE UNIVERSITY

Technical Data & Information

Milton and Tamar Maltz Performing Arts Center
1855 Ansel Road
Cleveland, OH 44106
216-368-6062
www.case.edu/maltzcenter
mpacinfo@case.edu

Case Western Reserve University
10900 Euclid Avenue
Cleveland, OH 44106

Table of Contents

GENERAL INFORMATION	3
LIGHTING EQUIPMENT	4
VIDEO PRODUCTION	5
AUDIO RECORDING	6
SOUND REINFORCEMENT	7
MICROPHONES	8
FURNISHINGS	10
ACOUSTICAL SHELL	13
SILVER HALL	14
KOCH RECITAL HALL	19
THE KALBERER ROOM	20
KESSELMAN GREEN ROOM	21
DRAWINGS	22
GRAND LECTERN	30
CHORAL RISERS	31
CANOPY MIC LOCATIONS	32
MAPS	33

Technical Data & Information
Milton and Tamar Maltz Performing Arts Center

General Information



The exterior of the Milton and Tamar Maltz Performing Arts Center in Cleveland, Ohio

HANDICAPPED ACCESS

Available via the West (side) lobby entrance. Stage access is available via the stage right wheelchair lift.

Wheelchairs and numerous disability-seating locations are available within the facility.

Assisted listening devices are available with both headset and neckloop receivers.

PARKING

Parking is available in Lot 82, which is adjacent to the west side of the building.

Additional parking is generally available in Lot 81, which is adjacent to the north side of the building.

At scheduled times, shuttles run from the Tinkham Veale University Center on campus to the West entrance.

SECURITY

Location: West Lobby Entrance

Coverage: 24 hours

Technical Data & Information
Milton and Tamar Maltz Performing Arts Center

Lighting

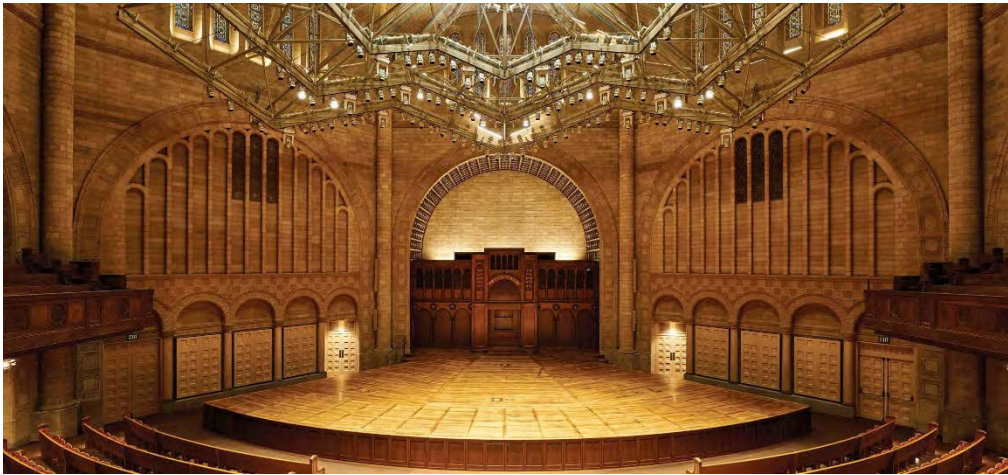

Lighting instruments hang from the beautiful glass and steel canopy in Silver Hall

A full complement of fixed ETC Selador lighting fixtures blanket the Silver Hall stage with even, warm coverage along with side and front lighting provided by Source Four fixtures. Control is centralized via a Strand Neo lighting board featuring a flat touch screen panel and iPad remote.

<u>Component</u>	<u>Qty</u>	<u>Description</u>	<u>Brand</u>
Control board	1	Neo Lighting Control	Strand Lighting
Flat screen monitor	1	Touch panel	Strand Lighting
Flat screen touch control	2	Vision Net	Strand Lighting
Lighting dimmers	12	2.4k ETC digital	ETC
Moving canopy fixtures	12	Selador Desire D40 LED	ETC
Static canopy fixtures	88	Selador Desire D40 LED	ETC
Theatrical instruments	24	10 degree Source Four, 750w	ETC
Theatrical instruments	24	14 degree Source Four, 750w	ETC

*MPAC retains a strict concert/lecture plot. Any refocusing of the Source Four fixtures will incur additional charges. Static units mounted on the Acoustic Canopy are fixed and cannot be refocused.

Video Production



Extensive video recording system located in the A/V control room of Silver Hall

The Maltz Performing Arts Center is equipped with the latest in camera and recording technology. Our facility allows clients to choose exactly how they wish to capture their event. We offer an entire range of possibilities; from a simple, single camera archival recording to a fully produced, multi-camera, dynamic HD video recording with the addition of livestreaming, lower third graphics, special effects and post-production editing. Our system highlights include the following:

- Five Telemetrics PTZ RoboEye cameras capture events from *multiple* angles
- Integrated Grass Valley Director video switcher allows for seamless transitions
- Excellent recording results from our AJA Ki Pro & Crestron Capture HD Pro units
- Distinct video presentations illuminated by Christie HD DLP laser projectors
- Multiple sources effortlessly alternate via our Analog Way Seamless Switcher
- High quality, portable Plura monitors onsite in a wide variety of sizes

Audio Recording



ProTools software is used for high quality audio recordings of live performances

Our facility features a dedicated sound booth, equipped with everything a recording engineer needs in order to create the highest quality, multi-track audio recordings. Microphone placement is effortless and wide-ranging using the extensive collection of microphone stands and overhead Servoreeler lines. Likewise, signals coming from the stage are easily patched and routed using the Dante Controller software program. Our equipment highlights include the following features:

- Record up to 32 channels using ProTools software on our Apple MacBook Pro
- Millennia microphone preamps provide superior incoming signal quality
- Integrated Dante controller allows for flexible input and output patching
- Denon SD/USB Recorder available as an alternative or backup recording format
- Retractable overhead mic and filament lines allow for flexible mic positioning
- ATC nearfield speakers provide recording engineers with accurate monitoring

Sound Reinforcement



View from the Front of House overlooking the Yamaha CL3 mixing console

The Maltz Performing Arts Center meets the challenge of sound reinforcement in a seven-sided hall with the very best equipment and technology. Typical event needs are met by the use of our in-house RANE audio program along with the installed D & B speaker system. Likewise, larger events that require additional power may call upon our Yamaha CL3 digital mixing console as well as our Martin Sound MLA line array units. Here are some of our reinforcement highlights:

- Front of House mixing is accomplished using our Yamaha CL3 digital console
- Integrated Dante System and Yamaha RIO boxes for flexible patching of inputs
- D & B Voice Lift sound system and amplifiers provide excellent sound quality
- Choice of handheld, lavalier or countryman style Shure wireless microphones
- Martin Sound floor-mounted MLA line array units for live bands or big events
- Williams Sound Assisted Listening System for our hearing-impaired patrons

Microphones



Collection of a wide variety of microphones for use by our valued clients

With an extensive and ever-expanding microphone collection, the Maltz Performing Arts Center can provide our customers with the flexibility to create the best audio possible. Whether it's a high-profile speaker at the podium, a piano soloist encompassed by a symphony orchestra or a group of dynamic vocalists, the correct microphone is within easy reach. Choosing reinforcement or recording is easy; our microphones can cover any application. Common uses include:

- Schoeps Colette Series microphones provided unparalleled recording quality
- Shure Beta 87 Series wireless vocal microphones allow for freedom of movement
- Sennheiser Evolution Series microphones combine high quality and flexibility
- Audio-Technica gooseneck microphones capture the spoken voice at the podium
- Earthworks Flexwand microphones define ease-of-use for groups of voices
- Instrument microphones from Shure, Sennheiser and AKG maximize options

Technical Data & Information
Milton and Tamar Maltz Performing Arts Center

Microphones

<u>Brand</u>	<u>Qty</u>	<u>Model</u>	<u>Description</u>
AKG	2	C414XLS	Large diaphragm - condenser
Audio-Technica	2	AT4021	Cardioid instrument - condenser
Audio-Technica	2	ES915C24	Gooseneck cardioid - condenser
Audix	2	MB5050	Carbon fiber boom - condenser
Earthworks	1	PM40	Piano mic system - condenser
Earthworks	6	FW730	Choir Flexwand - condenser
Schoeps	2	CCM2	Open cardioid - condenser
Schoeps	2	CCM41	Super cardioid - condenser
Schoeps	6	MK2	Omnidirectional - condenser
Schoeps	2	MK2H	Omnidirectional - condenser
Schoeps	4	MK21	Wide cardioid - condenser
Schoeps	2	MK22	Open cardioid - condenser
Schoeps	4	MK4	Cardioid - condenser
Schoeps	2	MK5	Switchable - condenser
Sennheiser	4	E945	Super cardioid - dynamic
Sennheiser	2	E906	Super cardioid - dynamic
Sennheiser	2	MD441-U	Super cardioid - dynamic
Shure	8	Beta 87A	Super cardioid - condenser
Shure	2	Beta 52A	Super cardioid - dynamic
Shure	4	Beta 98AMPC	Cardioid miniature - condenser
Shure	8	MX150BCTQC	Submini lav mic - condenser
Shure	4	MX153TOTQC	Countryman headset - condenser
Shure	8	MX412DC	Desktop cardioid - condenser
Shure	4	SM81	Cardioid instrument - condenser

Technical Data & Information
Milton and Tamar Maltz Performing Arts Center

Furnishings



Clients can enjoy a meal onstage in Silver Hall during meetings or conferences

Tables & Chairs

<u>Item</u>	<u>Qty</u>	<u>Description</u>	<u>Brand</u>
Conductor's chairs	2	Steel frame, #157F091	Wenger
Director's chair	1	Aluminum, #S102	Cantoni
Folding chairs	24	Novite, black plastic	KI Furniture
Metal frame chairs	68	Red fabric, #N27F53	Izzy
Musician's chairs	135	Black fabric, steel frame	Wenger
Task chairs	4	Black fabric, adjustable	KI Furniture
Wood chairs	94	Custom, green fabric	Thos Moser
Wood chairs	260	Custom, red fabric	Thos Moser
Rectangular tables - 6'	6	Aluminum, brown	Southern Alum.
Rectangular tables - 8'	12	Aluminum, brown	Southern Alum.
Round tables - 5'	6	Aluminum, brown	Southern Alum.

Technical Data & Information
Milton and Tamar Maltz Performing Arts Center



Steinway & Sons Concert D grand piano shown onstage in Silver Hall

Ensemble Furnishings

<u>Item</u>	<u>Qty</u>	<u>Description</u>	<u>Brand</u>
Artist grand piano	1	Model D - 9' concert	Steinway & Sons
Acoustical shell units	12	Wood, custom	Tartan Group
Artist benches	2	Spade leg, black	Jansen & Sons
Baby grand piano	1	Model M - 6'	Steinway & Sons
Cello chairs	15	Black, #943151	Wenger
Cello riser	1	Wood, #R1511082	Kolberg
Choir risers	12	Tourmaster, 4-step	Wenger
Conductor's podium	1	Custom design	Reserve Millwork
Conductor's stands	3	Acrylic, clear	Wenger
Conductor's stand	1	Metal, black	Wenger
Ensemble stools	12	Black fabric, steel frame	Wenger
Music stands	160	Classic 50, black plastic	Wenger
Music stand lights	100	Diva D1, LED	Aria Lights
Sound shields	6	Acrylic, portable	Wenger

Technical Data & Information
Milton and Tamar Maltz Performing Arts Center



Multi-height Stagetek platforms with Wenger musician's chairs shown onstage in Silver Hall

General Furnishings

<u>Item</u>	<u>Qty</u>	<u>Description</u>	<u>Brand</u>
Full-length mirrors	8	Brown finish, #900452	Coaster Company
Grand lectern	1	Custom, wood - 32" width	Thos Moser
Medium lecterns	2	Custom, wood - 24" width	Thos Moser
Stagetek platforms - small	4	Black finish - 4'd x 4'w	Wenger
Stagetek platforms - large	10	Black finish - 4'd x 8'w	Wenger
Stagetek legs - 6"	48	Black finish	Wenger
Stagetek legs - 12"	24	Black finish	Wenger
Stagetek legs - 18"	24	Black finish	Wenger
Stagetek legs - 24"	24	Black finish	Wenger
Stanchions & Rope	16	Bronze, #310/841MN	Crowd Control
Step platforms	2	Gray carpeted - 3' x 3'	Wenger
Wardrobe racks	4	Metal frame, black	Whitmor

Acoustical Shell



The 13-piece acoustical shell helps performers onstage hear each other and clarifies sound for the audience

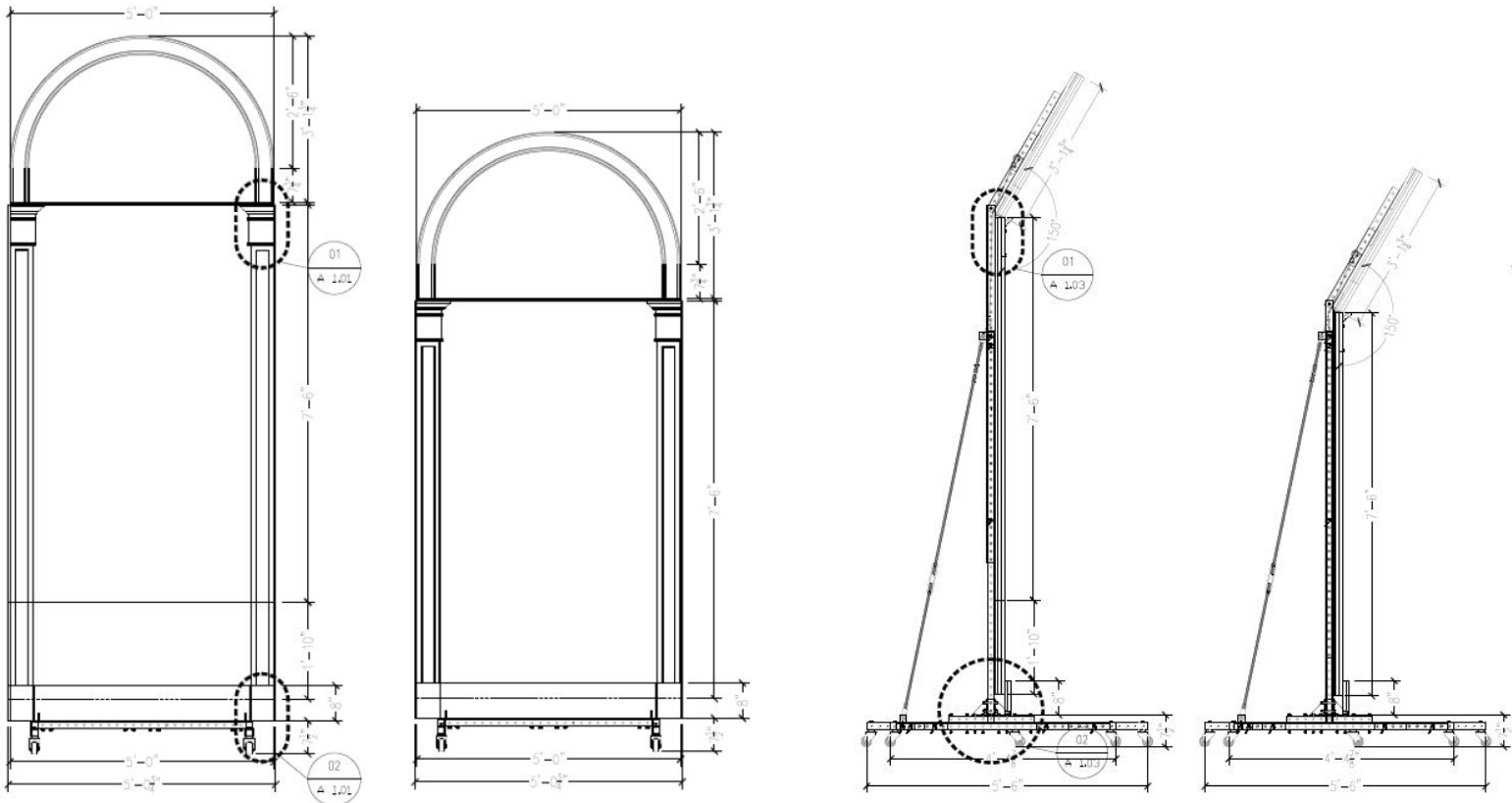

Technical Data & Information
Milton and Tamar Maltz Performing Arts Center

Silver Hall Technical Specifications

Nominal dimensions: 86' W x 98' D x 86' H

Standard usage: Concerts, Lectures, Ceremonies, Presentations

Seating capacity: (all totals include 492 balcony seats)

Concert stage configuration: 980

Ensemble stage configuration: 1069

Lecture stage configuration: 1192

Amplification

Ashley NE/NXP Series

Series 8250 - 3

Series 4004 - 2

Series 8004 - 1

D & B power amplifier

Model 10D - 2

Joe Meek 2-channel mic preamp

Twin Q2 - 1

Millennia 8-channel mic preamps

HV-3R Series - 6

Yamaha digital stage boxes

RIO 3224-D - 2

Assisted Listening System

Williams Sound System - T45

FM receivers - 42

Folding headphones - 42

Neckloops - 12

Audio Control Room

Nearfield monitors - ATC SCM20ASL - 2

Open-back headphones - Sennheiser HD800 - 1

Over-ear headphones - Sony MDR-7506 - 1

Studio monitor controller - DACS Headmaster - 1

Studio monitor stands - Ultimate MS9036B - 2

Technical Data & Information
Milton and Tamar Maltz Performing Arts Center

Audio Recording Consoles

ProTools System

- Apple MacBook Pro
- Avid HD Native
- Dante Virtual Soundcard (32 channels)
- Dante Interface – Focusrite RedNet 5 (32 channels)
- Avid HD I/O Interface
- Avid Artist Control
- Pace iLOK

SD/USB Recorder

- Denon DN-700R - 1

Servoreeler Positioning System

- System is Crestron/iPAD compatible
- Microphone positioning lines - 12
- Filament positioning lines - 12
- Trapeze bar - 1

Sound Reinforcement Consoles

Yamaha Digital Mixing Console – CL3

- 64 input channels
- 24 output channels
- Dante/iPAD compatible

Rane Processor - HAL1x/EXP5

- DR6 Touchscreen control
- 16 input channels
- Mute, EQ, Volume functions

Sound Reinforcement Speakers

D & B Voice Lift System – XC Series

- L & R Speaker columns - 4
- L & R Subwoofers - 2

Martin Sound Line Array System – MLA Series

- L & R Floor-standing line arrays - 4
- L & R Subwoofers - 4

Fulcrum Acoustic Vocal Monitoring System – FX Series

- Large 12" floor monitors - 2
- Small 8" floor monitors - 4
- Powered stand-mount monitors - 2

Technical Data & Information
Milton and Tamar Maltz Performing Arts Center

Stands - Konig & Meyer

Short telescoping mic stand #23320 - 2
Short mic stand with boom #25960 - 6
Stackable mic stand #26075 - 4
Tall tripod boom mic stand #21021 - 2
Tripod boom mic stand short reach #25200 - 6
Tripod boom mic stand long reach #25600 - 6

Standard Accessories

CD Player - Tascam CD-200SB - 1
Direct Box - Whirlwind DIR - 4
Dual direct box - Whirlwind DIRECT2 - 2
Gooseneck mic holder 18" - 2
Gooseneck mic holder 24" - 2
Microphone splitter - Rapcohorizon MS1 - 2
Press box - RCI MB-AVSDI816 - 1
Shock mounts - Audio Technica AT8410A - 10
Tabletop mic holders - OSS DS7200B - 4

Wireless System

Shure wireless quad receiver unit - ULXD4Q - 2
Shure Beta 87A wireless handheld microphones - 8
Shure ULXD1G50 belt pack transmitters - 4
Shure MX150BCTQG lavalier microphones - 4
Shure MX153TOTQG countryman-style microphones - 4

*Either belt pack (with lavalier or countryman-style microphones) or handheld microphones can be used with receivers. Presenters and performers can mix and match, with up to 8 channels per event.

Communications

Clear-Com belt packs - Helixnet HBP2X - 14
Cue light system - Leon Audio QLM16 - 12
Two-way radios - Motorola XPR6580 - 18

Power tie-in

Company Switch - Union Connector model CS-1-123
Cam-Lok or bare wire connections
3-phase, 400 amp

Technical Data & Information
Milton and Tamar Maltz Performing Arts Center

Video Monitoring - Plura monitors

Dual monitor 7" LCM-207-3G - 2
Small 19" LCM-119-3G - 2
Medium 23" LCM-123-3G - 2
Multiview 24" vectorscope MVM-124 - 1
Confidence monitors 40" DBM-140 - 2
Large screen monitors 55" DBM-155 - 2

Video Projection

Highlite 11k laser projector - Digital Projection WUXGA 3D
Retractable screen - 17'6" w x 9'10" h (210" w x 118" h)/16:9 aspect ratio - Draper Inc.

Video Recording

Camera controller and switcher - Telemetrics RCCP-1-STS - 1
Recording deck USB - Crestron Capture HD Pro - 1
Recording deck - AJA Ki Pro Rack - 2
Recording disk drives - AJA Ki-Stor 1USB - 8
Recording dock - AJA Ki-Stor Dock - 2
Robotic cameras - 30X, Telemetrics PTRE-1 PTZ - 5
Server unit - Grass Valley Nonlinear Production Center - 1
Static camera - Panasonic HE2PJ - 1
Video switcher unit - Grass Valley GV Director - 1
Digital mixing console for audio - Yamaha DM1000 - 1

Video Processing

Control Processor - Crestron PRO-3
Digital Graphics Engine - Crestron DGE-2
House Reference - Mutec iClockDP
Seamless Switcher - Analog Way QMX150
Touchscreen controller - Crestron TS Series
Video Router - Snell Vega Series

Video Accessories

Audio signal embedder - Sonifex RP-VHCMD16 Redbox
Blu-ray player - Oppo BDP105D Darbee Edition
Computer interface - AJA IO4K
Portable light stand set - Manfrotto 368B
Signal converters HDMI to SDI - AJA HA5
Signal converters SDI to HDMI - AJA HI5-Plus

Magic Sheet - Silver Hall

Down Lights

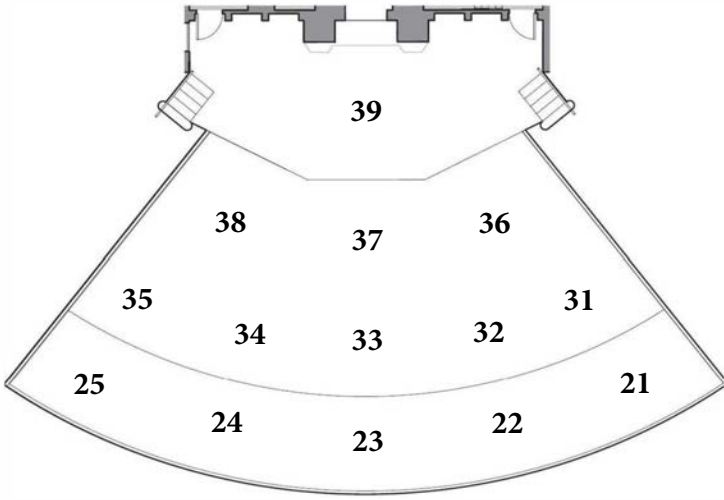

Front Lights

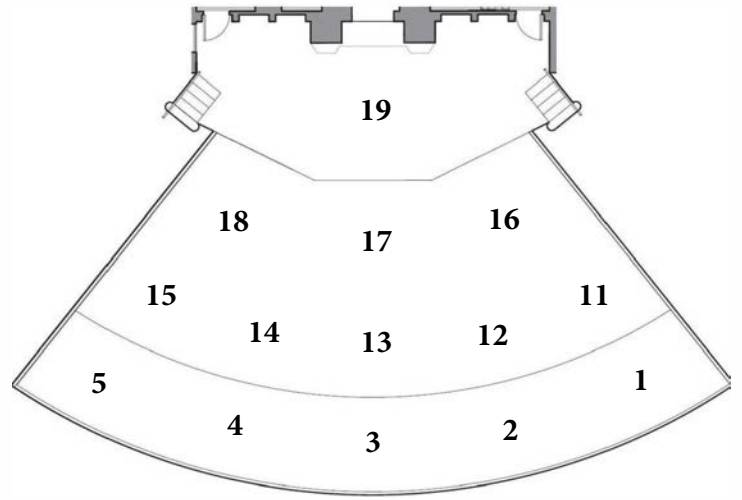

Side Lights

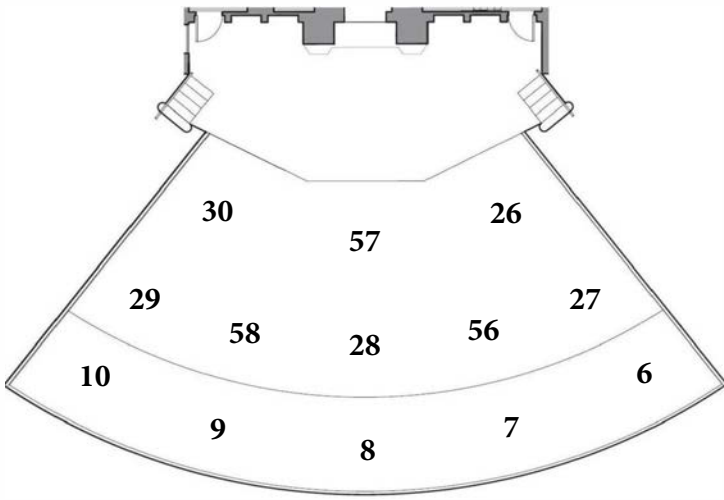

Moving Lights

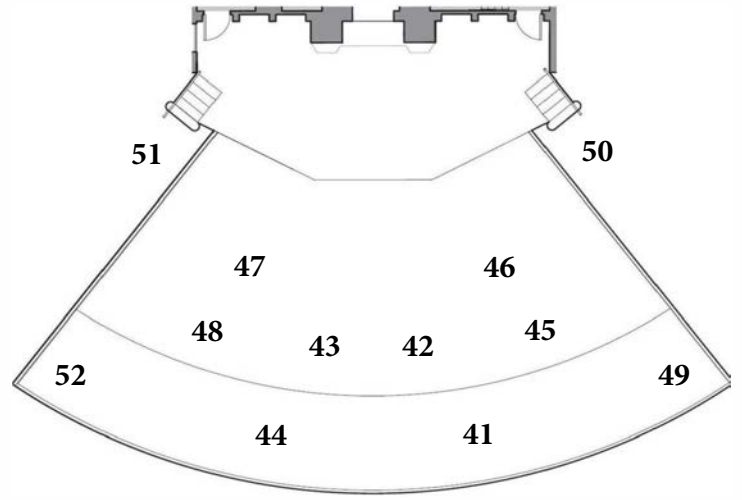

Special Purpose - Extension Up

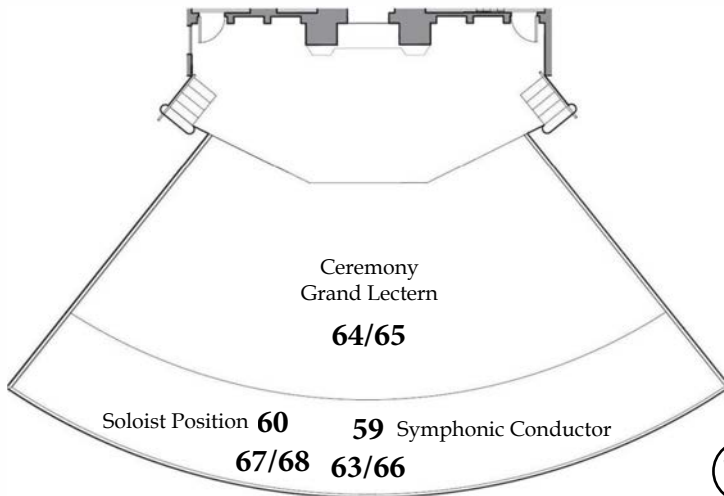

Special Purpose - Extension Down

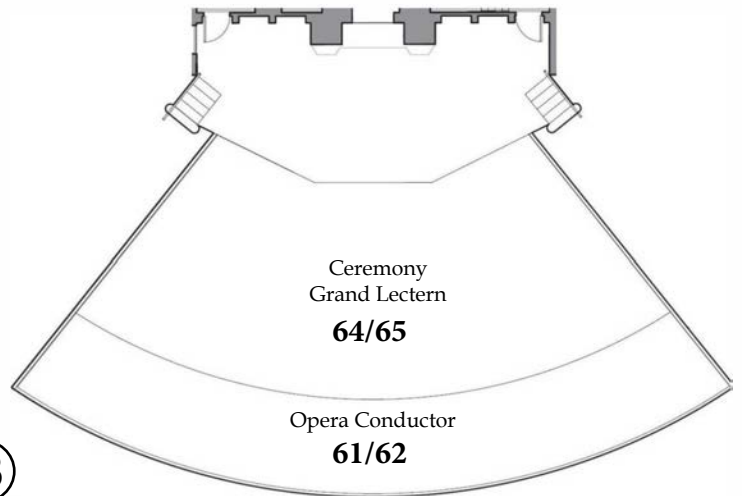

Technical Data & Information
Milton and Tamar Maltz Performing Arts Center

Bud and Katie Koch Recital Hall
Technical Specifications

Nominal dimensions: 23' W x 48' D x 16' H

Standard usage: Recitals, Lectures, Conferences, Receptions

Room capacity: 90

Amplification

Lab Gruppen Power Amps - E Series 12:2, 8:2

Millennia Mic Preamp - HV-3R Series

Assisted Listening System

Black Lion - PM8 MKII Mixer

Williams Sound System - PPAVP with FM receivers

Audio Recording

Denon DN-700R - SD/USB Recorder

Schoeps Colette MK2/CMC6 overhead microphones - 2

All signals may be patched to the Silver Hall Audio Control Room

Video Recording

Panasonic AW-HE40 PTZ HD camera with IP control - 1

Crestron Capture HD Pro USB Recording deck - 1

Video Projection

Christie DWU555-GS laser video projectors - house left and right

Draper retractable screens - 8'8" w x 4'10" h (104" x 58" h)/16:9 aspect ratio

Video Presentations

HDMI/VGA access via stage right floor pocket

Crestron DGE-2/PRO3 Control Processors

Oppo BDP105D Darbee Edition Blu-ray player

Wireless System

Shure wireless receiver unit - ULXD4D

Shure Beta 87A wireless handheld microphones - 2

Shure ULXD1G50 transmitters with lavalier or headset microphones- 2

Technical Data & Information
Milton and Tamar Maltz Performing Arts Center

Walter and Jean Kalberer Room Technical Specifications

Nominal dimensions: 23' W x 23' D x 15' H

Standard usage: Meetings, Lectures, Receptions, Control Room for A/V

Room capacity: 49

Amplification

Lab Gruppen Power Amp
E Series 4:2

Audio Recording

Denon DN-700R - SD/USB Recorder

Video Projection

Christie laser video projector
Model DWU555-GS - 5,400 lumens
WUXGA 1DLP resolution
Retractable screen - 9'8" w x 5'5" h (116" w x 65" h)/16:9 aspect ratio - Draper Inc.

Video Presentations

HDMI/VGA access via rack port
Control Processors - Crestron DGE-2/PRO3
Blu-ray player - Oppo BDP105D Darbee Edition

Wireless System

Shure wireless receiver unit - ULXD4D
Shure Beta 87A wireless handheld microphones - 2
Shure ULXD1G50 transmitters with lavalier or headset microphones - 2

Control Room Connections

The Kalberer Room can be used as a fully-functional A/V Control Room for Silver Hall
HD/SDI video connections via Coax/BNC - 16
Ethernet ports - 8
Analog audio channels - 64
Individual 20-amp electrical circuits - 6

Technical Data & Information
Milton and Tamar Maltz Performing Arts Center

Gerry and Jane Kesselman Green Room Technical Specifications

Nominal dimensions: 11'6" W x 20'6" D x 8' H

Standard usage: Guest hospitality, Dressing room, Lounge

Room capacity: 8

Amenities

Private, locking restroom
Refrigerator
Microwave oven
Ironing board with steam iron
Garment steamer
Overhead audio monitor
Wall-mounted video monitor
Closet with closet rod and hangers

Furniture

Leather sofa
Leather chair
Coffee table
Full-length mirror
Countertop
Storage drawers

Maltz Performing Arts Center - First Floor Overview

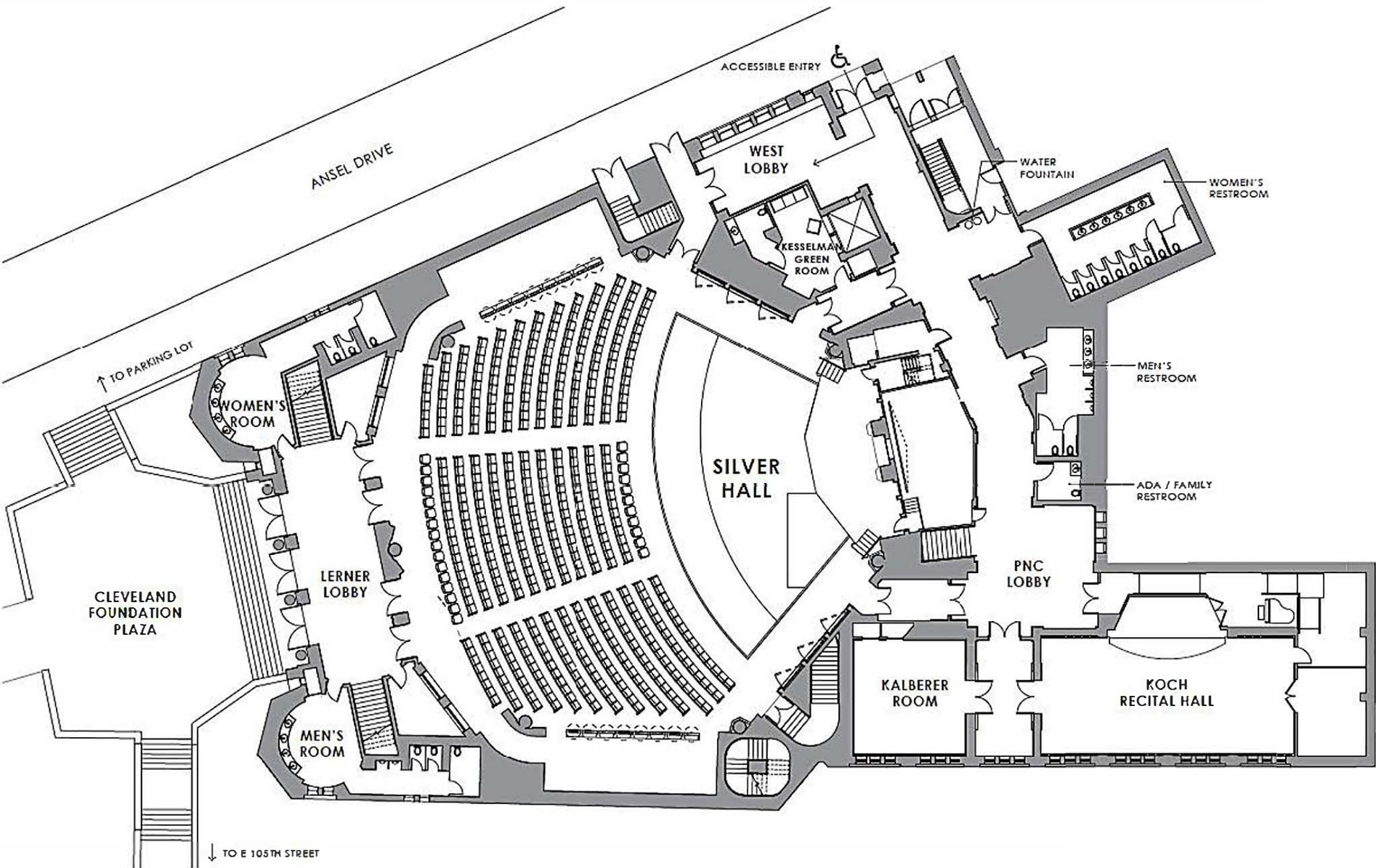

Concert Stage Dimensions

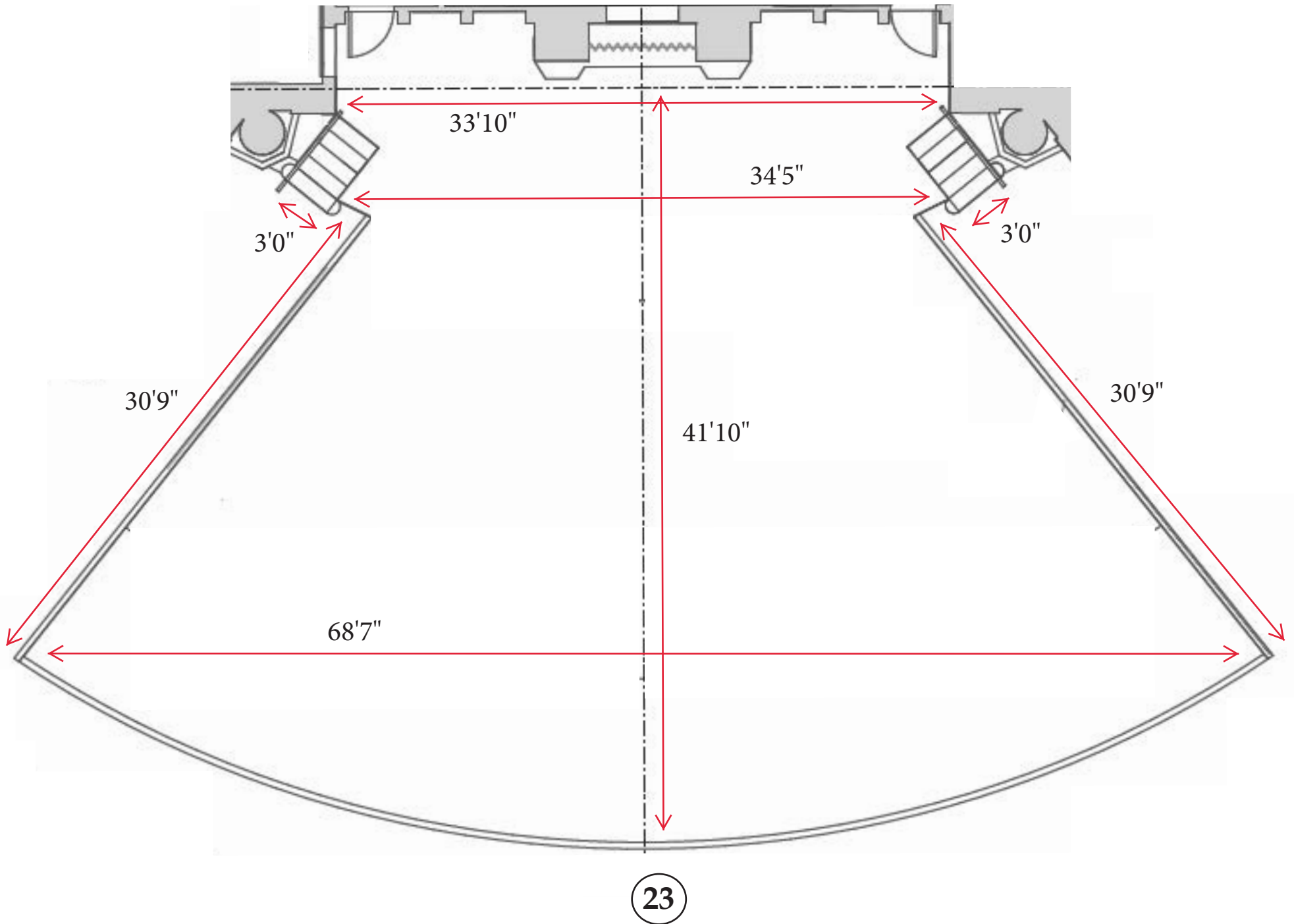

Ensemble Stage Dimensions

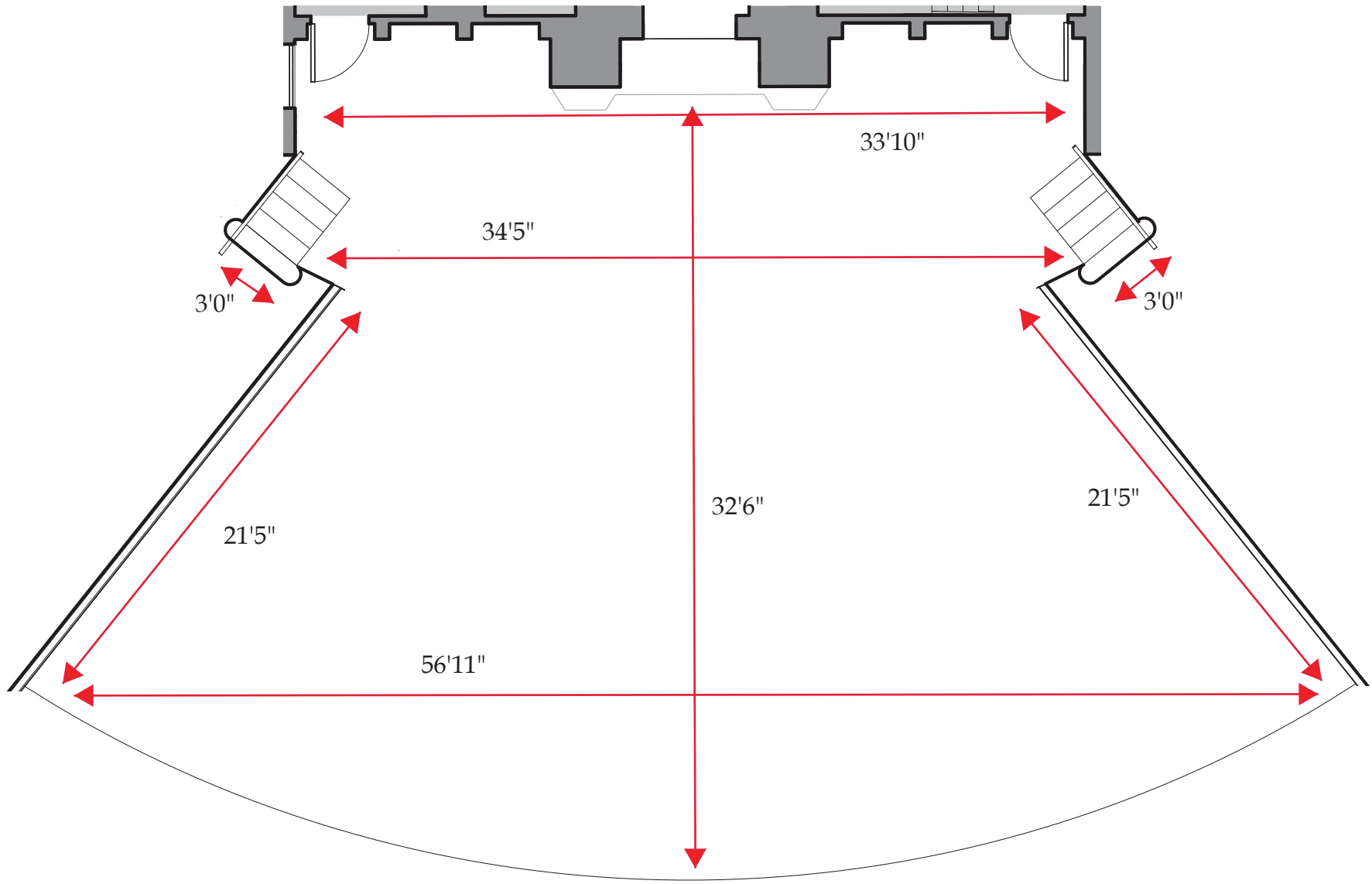

Lecture Stage Dimensions

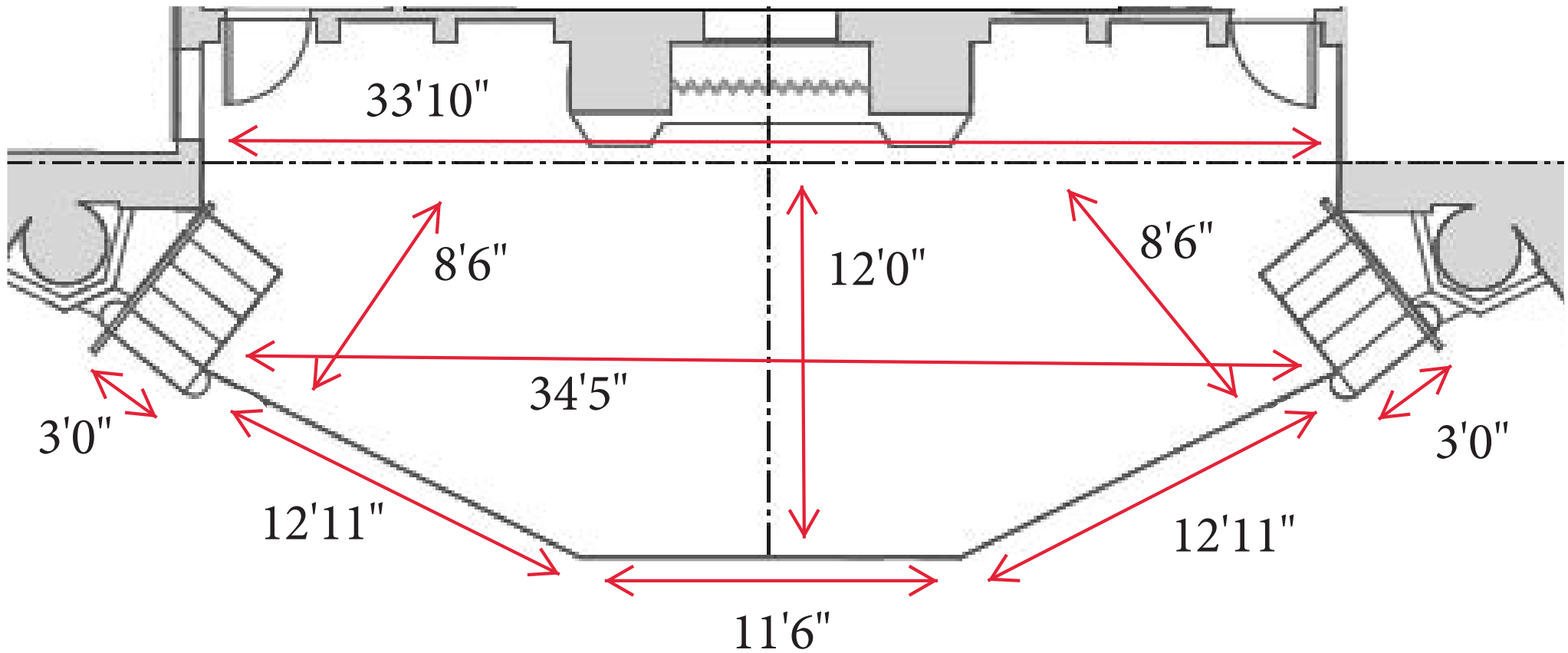

KOCH RECITAL HALL.

Stage extension with seating

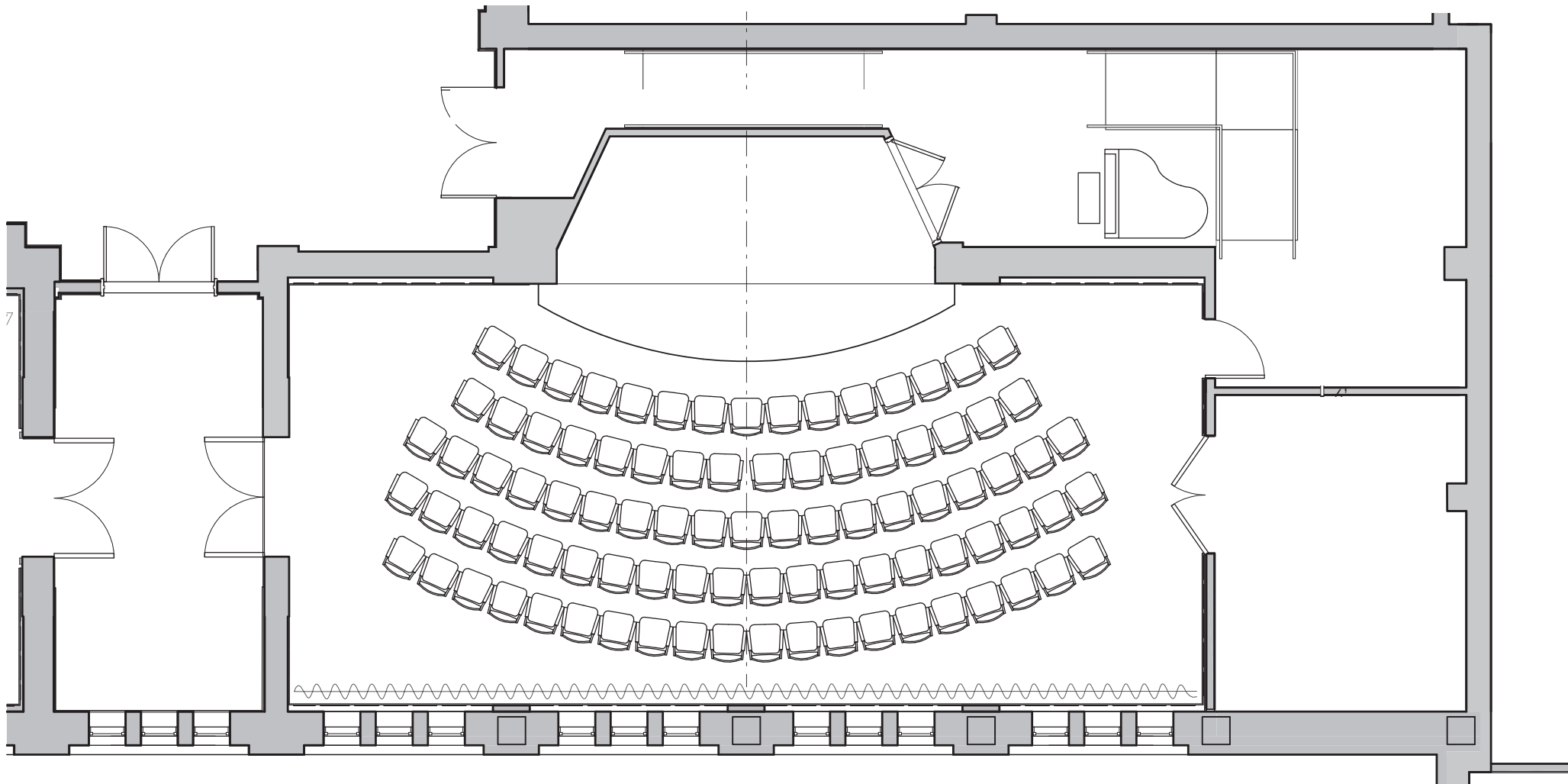

KOCH RECITAL HALL
Stage extension and
seating removed

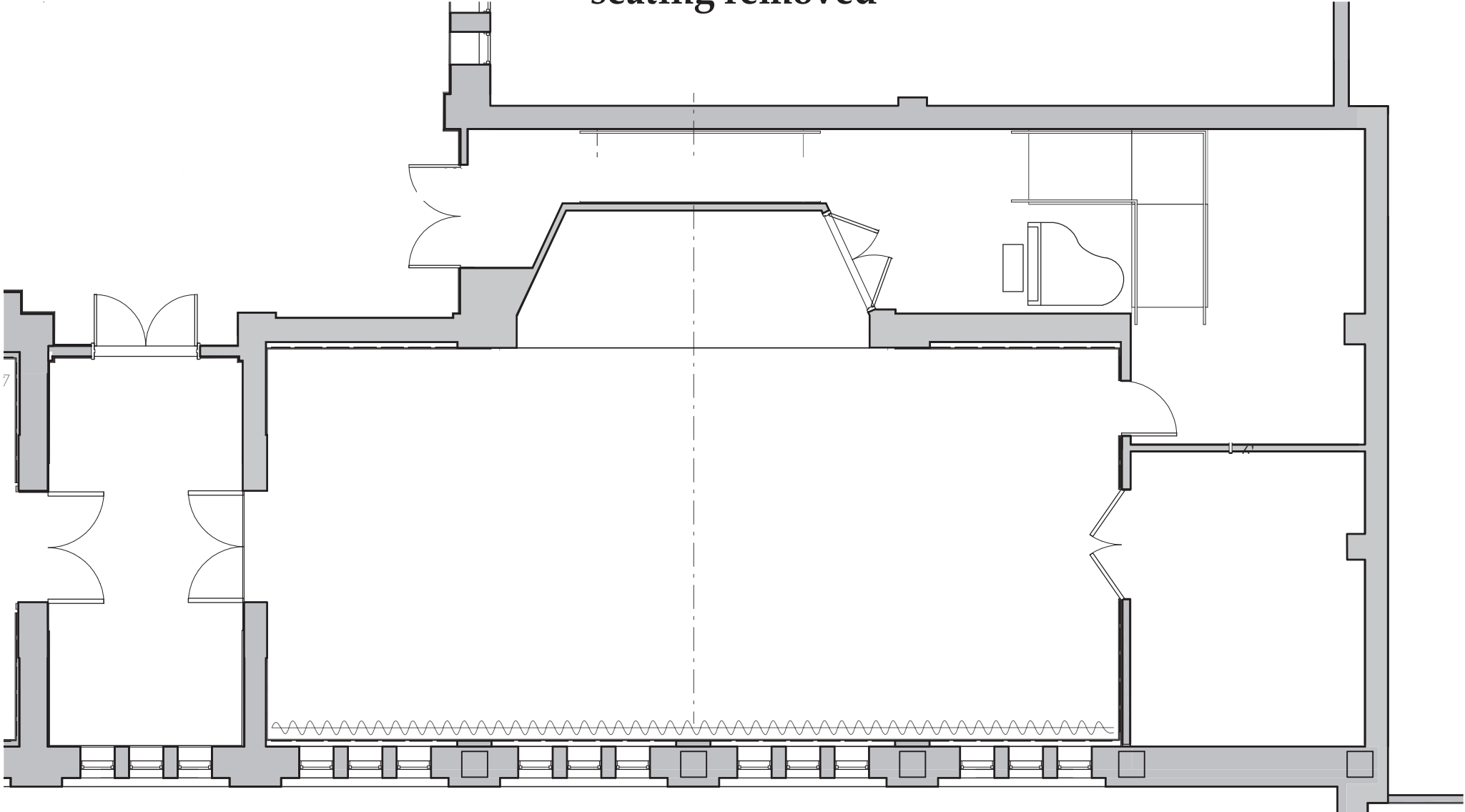

Koch Recital Hall Dimensions

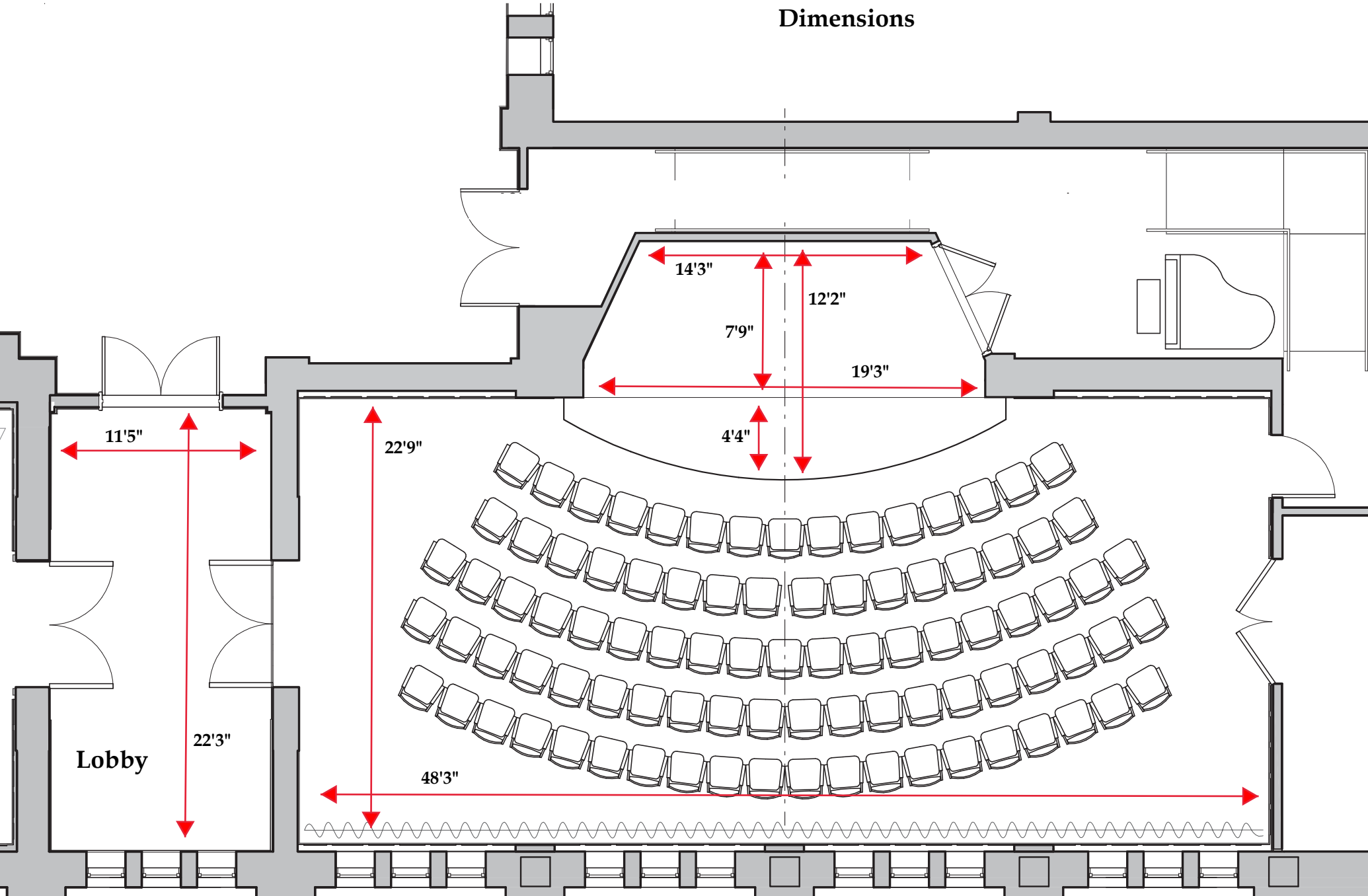

The Kalberer Room

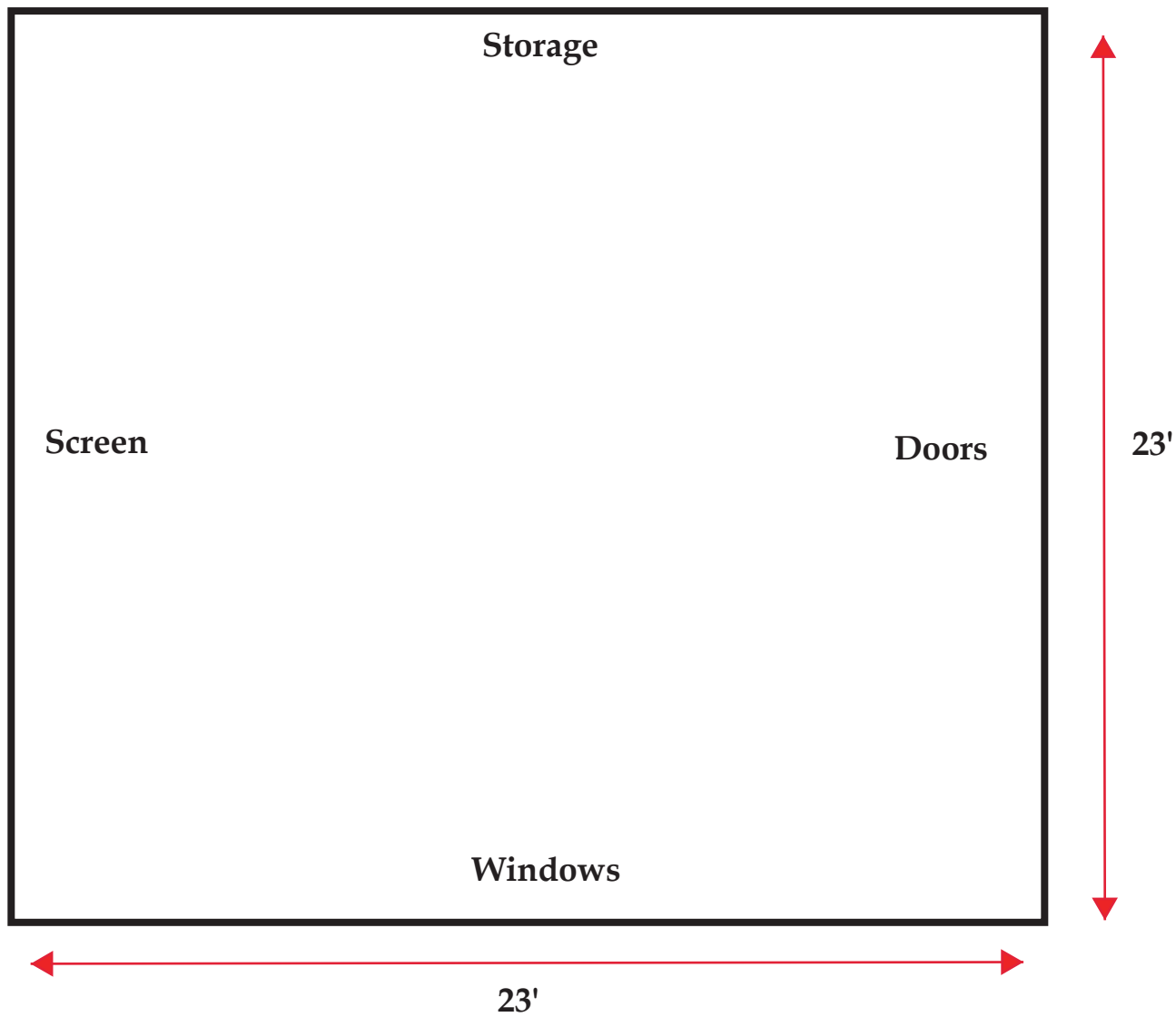

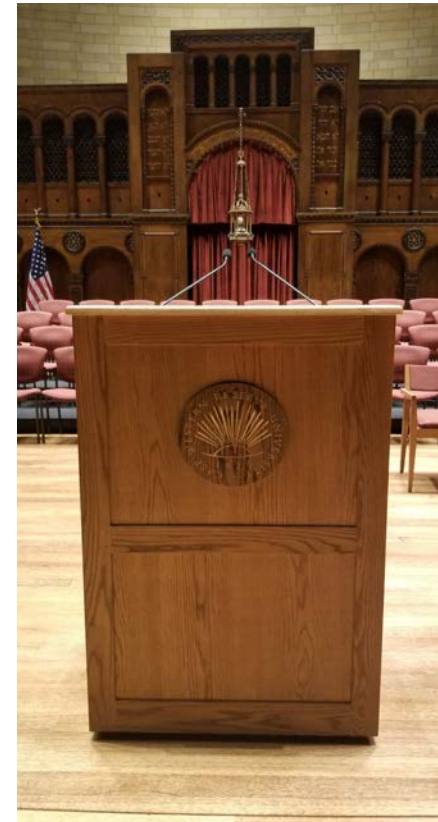
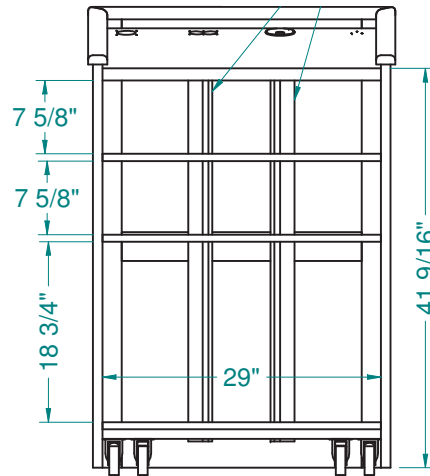
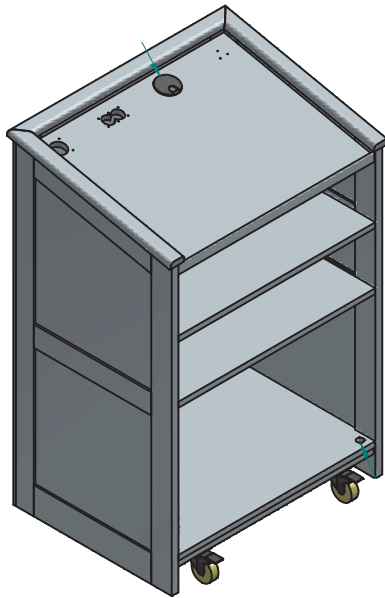
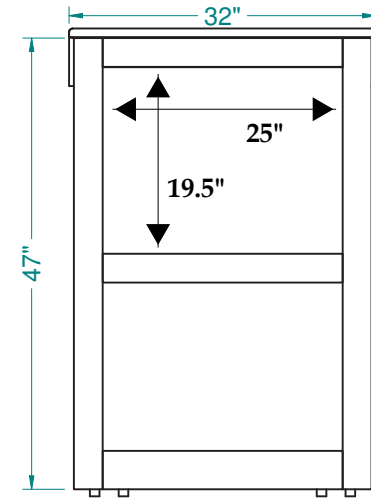
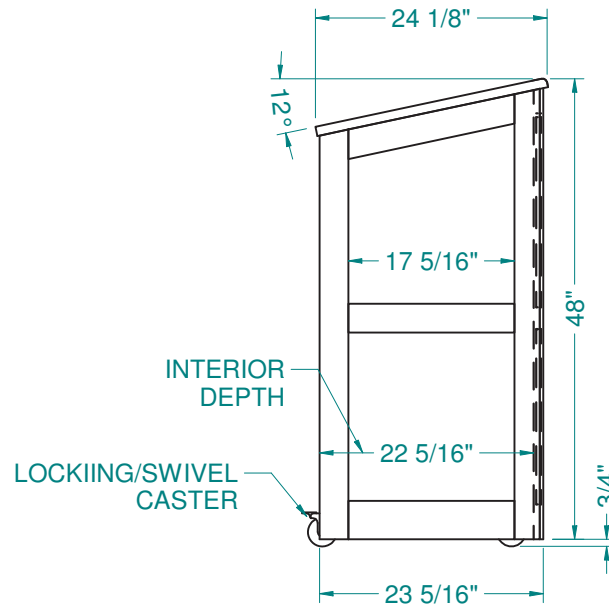
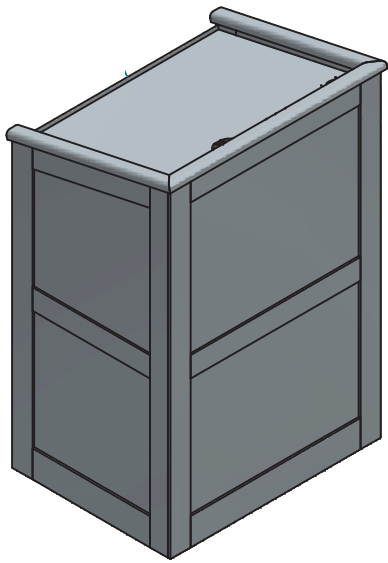

Grand Lectern

- 4'7" x 24" (1397 x 610 mm) unit 127 lbs (58 kg).
- Load rating at 125 lbf/ft² (6 kN/m²)
- Portable 3-step unit, accordion style design folds compactly.
- Ideal for groups that travel.
- Frame is 7/8" (22 mm) 14-gauge square tubing.
- Steps are 19/32" (16 mm) plywood covered with high quality polyester non-woven Grey carpet made from 100% certified post-consumer recycled plastic bottles.
- Step edging is Grey powder-coat paint finish.
- Foot-pedal activated cross brace locks leg structure automatically.
- Built-in reversibility allows for straight or semi-circular configuration.
- Units have 3" (76 mm) non-marring rubber casters, built-in stair glides, two 4" (102 mm) wheels for positioning.
- Available in 4' (1219 mm) and 6' (1829 mm) lengths with 18" (457 mm) usable step depth and 24" (610 mm) usable step depth.

Choral Risers

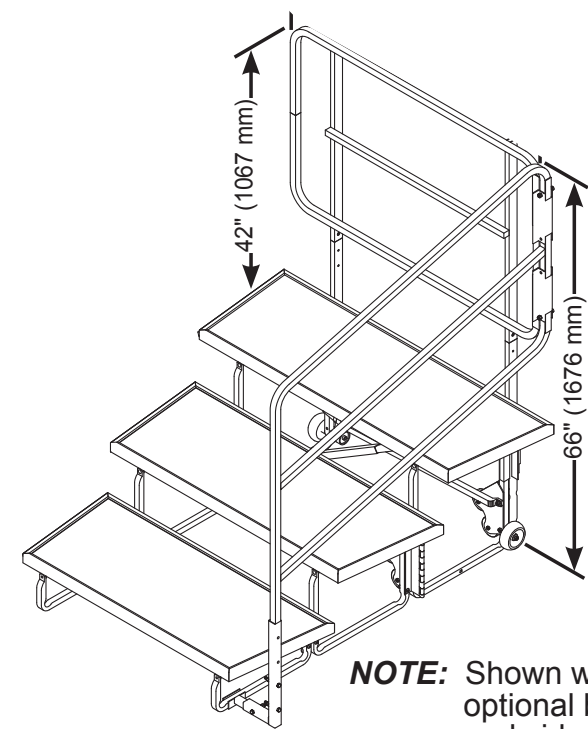

NOTE: Shown with optional back and side rail.

- 24" (610 mm) unit 55 lbs (25 kg).
- 4th Step Addition attaches to corresponding Tourmaster Riser with integral leg clamps, no tools needed. Must be removed prior to folding for storage.
- Back rails have positioning wheels so that backrail support bar does not encumber moving riser in setup position. Back rails break down without tools for easy travel.
- Back rails are Grey metallic powder-coat paint finish with quick and easy clamp attachment to 3-step unit or 4th step addition. 42" (1067 mm) height meets OSHA standards.
- 024E763 4' (1219 mm) Back rail 24 lbs (11 kg).
- 024E778 6' (1829 mm) Back rail 31 lbs (14 kg).
- 024F017 Optional Side rails 8 lbs (22 kg) are Grey metallic powder-coat paint finish and clamp to both the Back rail and the Riser.

5' 1" (1549 mm) Riser

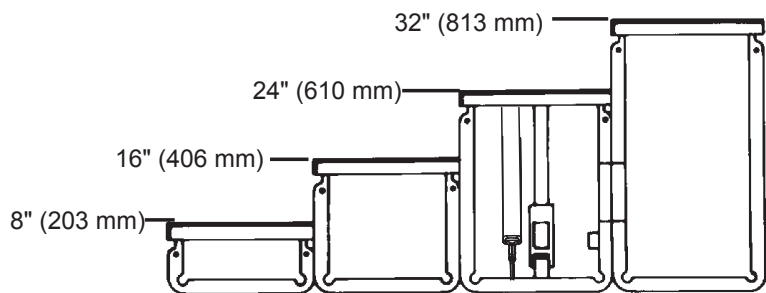
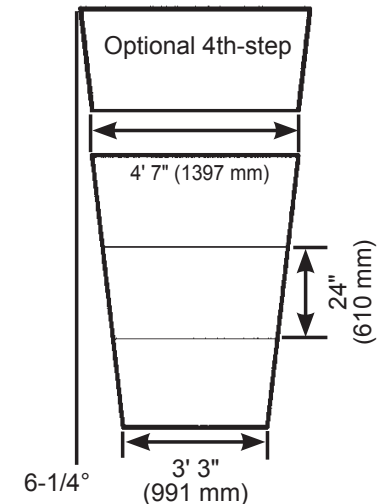

Shown with Optional 4th-Step

Canopy microphone drop and filament line locations

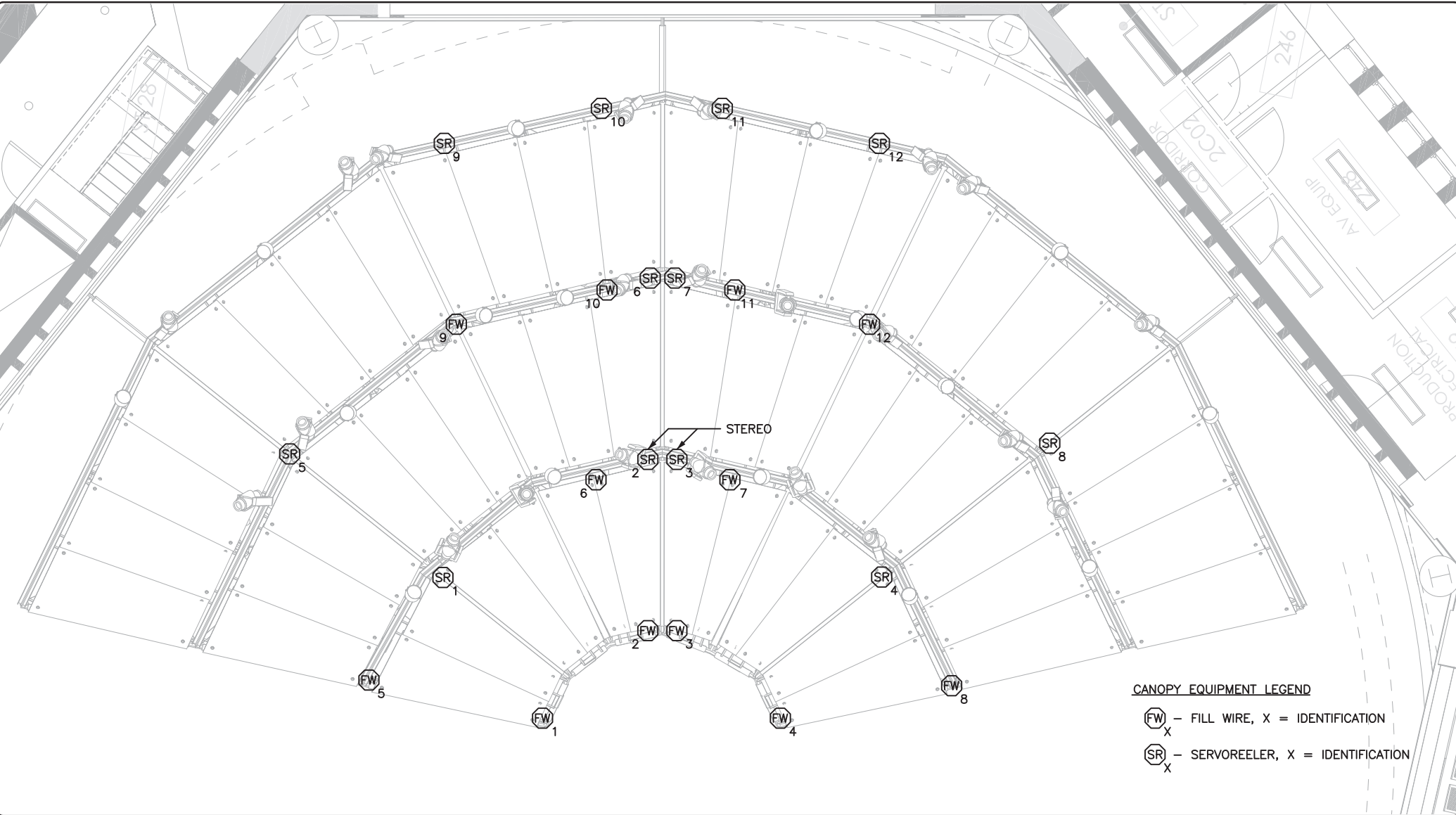

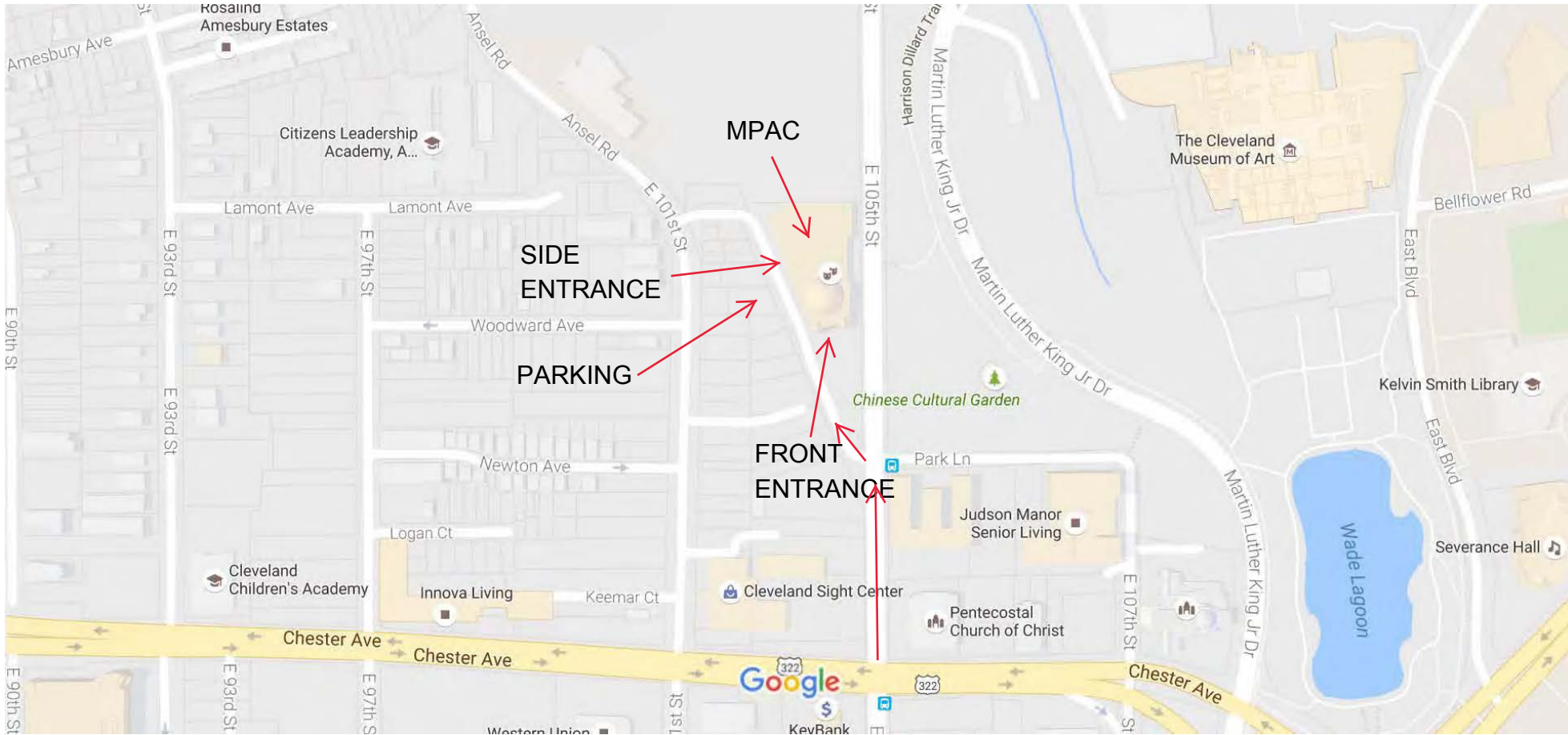

Maltz Performing Arts Center



Map Legend

Shuttle Stops:

- GreenLink
- BlueLink
- Commuter
- Evening North
- Evening South
- The Heights AM Loop
- East 119th (Route A)
- UCRC
- 59/61 Route (Route B)
- Shelter at this stop

Other Icons:

- Parking
- Restaurants
- Police
- RTA Rail
- Hotels

